

this document downloaded from

# vulcanhammer.info

the website about  
Vulcan Iron Works  
Inc. and the pile  
driving equipment it  
manufactured

Visit our companion site  
<http://www.vulcanhammer.org>

## Terms and Conditions of Use:

All of the information, data and computer software ("information") presented on this web site is for general information only. While every effort will be made to insure its accuracy, this information should not be used or relied on for any specific application without independent, competent professional examination and verification of its accuracy, suitability and applicability by a licensed professional. Anyone making use of this information does so at his or her own risk and assumes any and all liability resulting from such use. The entire risk as to quality or usability of the information contained within is with the reader. In no event will this web page or webmaster be held liable, nor does this web page or its webmaster provide insurance against liability, for any damages including lost profits, lost savings or any other incidental or consequential damages arising from the use or inability to use the information contained within.

This site is not an official site of Prentice-Hall, Pile Buck, or Vulcan Foundation Equipment. All references to sources of software, equipment, parts, service or repairs do not constitute an endorsement.

# Static and dynamic analysis of an offshore mono-pile windmill foundation

*L. Kellezi and P. B. Hansen*

*GEO - Danish Geotechnical Institute, Lyngby, Denmark*

## **Introduction**

Different foundation concepts have been presented and applied to offshore windmill turbines designed and constructed all over the world. The advantages and disadvantages of different concepts are already outlined and research from universities and private companies continues with this respect.

The choice of the foundation concept for an offshore windmill turbine is governed by several factors, which include soil conditions, the water depth at the location, the scour and erosion, the capacity of the turbines, the foundation cost etc. It is investigated that for offshore windmill turbines the foundation costs are approximately 25% of the total cost [1].

There are basically three types of foundations applied to different windmill parks. These are: gravity based, skirted and piled foundations.

Piled foundations are the most common foundations for offshore structures. Driving the piles into the seabed is the standard method of installation [2].

Considering the soil conditions and other factors the mono-pile foundation concept was chosen for the windmill park at Horns Rev, Denmark. Such concept is also applied at Utgrunden and Bockstigen in Sweden and other places. Large diameter mono-piles are generally used for offshore windmill turbines placed at shallow water.

A lot of progress has been made in the last decades towards the development of engineering methods for the static and dynamic analysis of the pile foundations.

Different approaches can be adopted in solving the problem. The p-y approach or Winkler model, [3-5] has been widely used to design piles subjected to lateral static or dynamic loading. Based on this approach the lateral soil-structure interaction can be modeled using empirically derived nonlinear springs and dashpots.

## 2 L. Kellezi and P. B. Hansen

More rigorous finite element methods (FEM), which allow application of soil constitutive modeling and soil-pile nonlinear interaction, have been developed lately. Some representative FEM applications regarding pile foundation design are given by [6-9] where a series of 3D FEM studies were conducted on the behavior of piles under static loads.

For dynamic loads the problem can be considered as viscous-dynamic with material damping included, [10-11], or nonlinear-dynamic depending on the current situation. A structure resting on pile foundations and subjected to dynamic vibrations with small amplitudes can be analyzed as a viscous-dynamic problem. However piles under earthquake excitations or pile driving analysis, which is associated with large amplitudes of vibrations and penetration, should be considered as a strongly nonlinear-dynamic problem, [12-13].

The mono-pile windmill foundation at Horns Rev is analyzed here for maximum static and dynamic loads. 3D nonlinear FEM design is carried out for static loads employing ABAQUS program. 3D axisymmetric viscous-dynamic analysis is carried out for dynamic loads as small vibration amplitudes are expected for a windmill turbine foundation structure. Self developed FEM programs are used in this case.

### **Description of the static model**

The approaches based on FEM analysis have the advantage of taking into account the initial conditions, nonlinear pile-soil interaction and nonlinear soil behavior.

In the current analysis the model is composed of two 3D parts named respectively. 'Soil' and 'Pile'. Each of the parts is partitioned creating different layers for the soil and different sections for the pile.

The material properties for the soil are assigned based on the offshore geotechnical investigation carried out at Horns Rev. The geometry and material properties for the pile are based on a preliminary pile design which consists of a 4 m diameter and 22 m pile length.

The initial conditions of type stress are defined before the pile is installed. The effective body forces are calculated to account for geostatic equilibrium before the loads at the top of the pile are applied.

Taking into account the symmetry half of the model is considered. Elementary and symmetry boundary conditions are applied.

The extreme static horizontal load  $H = 2503$  kN and the bending moment  $M = 84983$  kNm, act at the seabed level. Because of symmetry the horizontal force is applied as a concentrated force with value  $H = 1251.5$  kN and the moment is applied as a set of two vertical concentrated loads with opposite signs and value respectively.  $V = 10622.9$  kN at the pile top;

In the 3D analysis the stiffness of the elastic-plastic surrounding soil is well accounted. In addition, the limiting pressure either due to wedge failure or full flow around the pile is modeled correctly.

The finite element mesh is designed and generated using isoparametric brick elements with reduced integration for the soil and the pile. The 3D model shown in Figure 1 is asymmetric because of the asymmetric loads applied and it has the corresponding size to reach an accurate modeling of the infinite layered soil domain.

#### Pile modeling

The pile is modeled from the tip elevation  $-32.9$  m to the top elevation  $-10.9$  m above the seabed. The part over the seabed (1 m long) is needed in the model as otherwise the soil will go over the pile violating ultimate state which does not correspond to the real situation. The weight of this part is neglected.

The steel pile tube is considered to behave linearly elastic and modeled as a cylindrical structure. Different elastic parameters are assigned along the pile length because of thickness variation with depth. These parameters are calculated making sure that the modeled pile has the same rigidity as the real one.

Considering the weight, the pile is assumed completely filled with soil of the same profile as out of the pile. The material properties are given in Table 1.

Table 1 Mechanical data for the pile

	Depth (m)	E (kN/m <sup>2</sup> )	$\gamma_{eq}$ (kN/m <sup>3</sup> )	$\nu$
Section 1	1.4	2.02E7	22.95	0.3
Section 2	9.1	2.18E7	23.17	0.3
Section 3	12.4	2.02E7	22.94	0.3
Section 4	14.7	1.63E7	19.47	0.3
Section 5	22.0	1.23E7	20.31	0.3

#### Soil modeling

The layered soil conditions at the location are modeled using design parameters with partial coefficients 1.0 based on the data derived from CPT tests, vibrocoring, geotechnical borings and laboratory tests. The data show sand profile from the seabed to a depth of 13.75 m, following with organic sand to a depth of 21.75 m and continuing with sand deeper on.

The data derived correspond to every 0.5 m depth. When the soil parameters are very close to each other some of these 0.5 m thick layers are merged into one layer with average values of the material parameters. So in all, the soil profile is approximated with 13 different layers with derived designed parameters taken as average values as shown in Table 2.

From the soil profile it can be noted that at depth 13.5 m to 20 m a layer of organic sand is located having rather low value of the friction angle.

#### 4 L. Kellezi and P. B. Hansen

Mohr-Coulomb (MC) constitutive model is applied first combined with MC Hardening in ABAQUS. This is an extension of the classical MC failure criterion. It is an elastic-plastic model that uses a yield function of the MC form. This yield function includes isotropic cohesion hardening/softening.

Table 2 Geometric and mechanical data for the soil

Soil Layers	Name	Depth (m)	E kN/m <sup>2</sup>	$\gamma/\gamma'$ kN/m <sup>3</sup>	$\phi$ grade	$\psi$ grade	$\nu$
Layer 1	Sand	1.0	31800	20/10	42.0	12.0	0.3
Layer 2	Sand	3.5	57100	20/10	43.5	13.5	0.3
Layer 3	Sand	5.5	52534	20/10	42.5	12.5	0.3
Layer 4	Sand	6.5	44100	20/10	41.7	11.7	0.3
Layer 5	Sand	7.0	58200	20/10	43.2	13.2	0.3
Layer 6	Sand	8.5	72170	20/10	44.3	14.3	0.3
Layer 7	Sand	10.0	52950	20/10	43.1	13.1	0.3
Layer 8	Sand	11.5	35400	20/10	40.3	10.3	0.3
Layer 9	Sand	12.5	23530	20/10	37.2	7.2	0.3
Layer 10	Sand	13.5	13600	20/10	33.8	3.8	0.3
Layer 11	Org. sand	20.0	3135	17/7	21.6	0.0	0.3
Layer 12	Org. sand	21.04	12950	17/7	31.2	1.2	0.3
Layer 13	Sand	41.8	36800	20/10	37.8	7.8	0.3

Alternatively Drucker-Prager material model with non-associated flow rule was used with parameters derived from the MC model as referred to [14]. Based on the available soil design parameters dilatancy angle  $\psi$  is calculated as a function of the friction angle, [15]. Some sensitivity analyses related to soil material modeling are carried out as well. Dilatancy angle  $\psi = \phi$  was used as an alternative for each layer. It seems that this doesn't effect pile deformation considerably.

#### Soil-Pile Contact Modeling

'Contact pair' models nonlinear behavior in the soil-pile interface. The pile outer surface is chosen as a 'master surface' and the soil surface in contact with the pile as a 'slave surface'.

The contact-definition between the pile and the soil is divided into two parts: radial contact direction and axial direction. Zero friction is assumed in the initial step. Another step is added for initial loading when friction is activated.

'Small sliding' contact of two bodies with respect to each other is employed based on the engineering judgment. The small sliding capability can be used to model the interaction between two deformable bodies or between a deformable body and a rigid body in 3D.

An elastic-plastic model is used to describe the behavior at interfaces. The Coulomb criterion is used to distinguish between elastic behavior and plastic behavior or slip.

As a final reasonable choice the friction = 0.67 with a slip tolerance of 0.005 for sand –steel contact was employed.

**Calculations and Results**

The calculation procedure consists of several steps. It starts with the initial state, which is carried out in the geostatic equilibrium calculations.

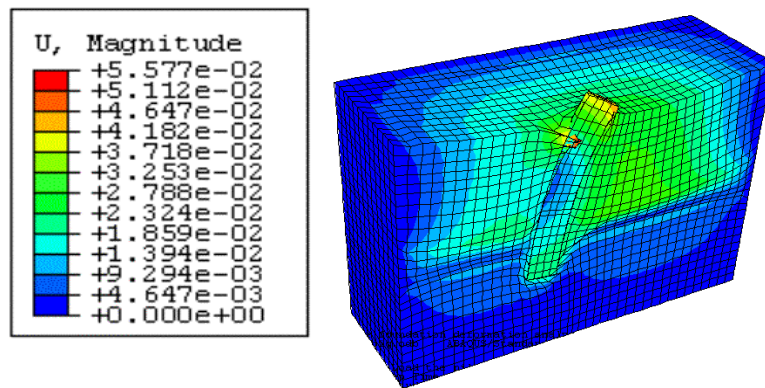

Figure 1 Total model deformations

Then the combined static load H and momentum M are applied starting from zero to the maximum value giving the maximum elastic and plastic pile deformation. After that the unloading is carried out inactivating the combined loads. At the end of this stage the plastic pile deformation can be investigated.

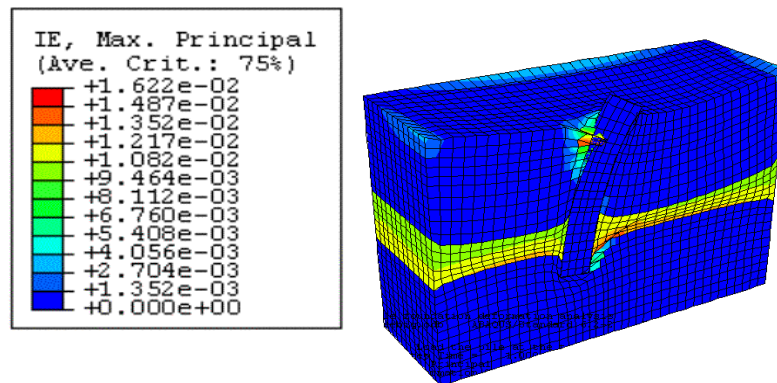

Figure 2 Inelastic maximum principal strain.

Results concerning total deformations during loading are given in Figure 1. The inelastic maximum principal strain component for the whole model is given in Figure 2.

The loading and unloading curves of force-displacement relationship at the pile top are given in Figure 3.

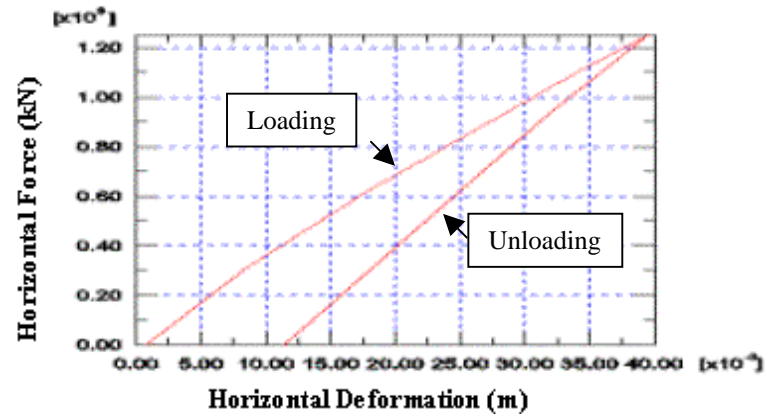

Figure 3 Horizontal deformation-force curves during loading and unloading.

As a conclusion, for the 22 m pile length the maximum horizontal deformation at the seabed level is evaluated to be 35 - 40 mm and the rotation angle 0.37 - 0.38°. The plastic horizontal deformation is evaluated to be 10 - 12 mm with a rotation angle quite under 0.25°.

Different FEM meshes were used during the calculation as a sensitivity analysis. It seems that the pile behavior is not sensitively differing for finer meshes especially near the pile. So the model accurately simulates the flow around the pile and gives a realistic estimation of the soil-pile elastic-plastic deformation.

### Description of the dynamic model

During the operation phase, the mono-pile windmill foundation is expected to vibrate with small amplitudes. So a 3D viscous-dynamic problem is appropriate in this case.

The sequence of development from one time step to the next or the time domain concept is considered more appropriate in this analysis as the dynamic loads are given as time series, transient functions.

The pile and the soil are modeled in one dynamic model employing solid finite elements in axisymmetric conditions different from the previous static analysis where a full 3D modeling was employed.

The axisymmetric modeling is a semi-analytical FEM process. The analysis is 3D with 3DOF at each node, however it is only necessary to discretize the

problem in a radial plane. A further development of the model described in detail in [16] is used in the current analysis for layered soil conditions.

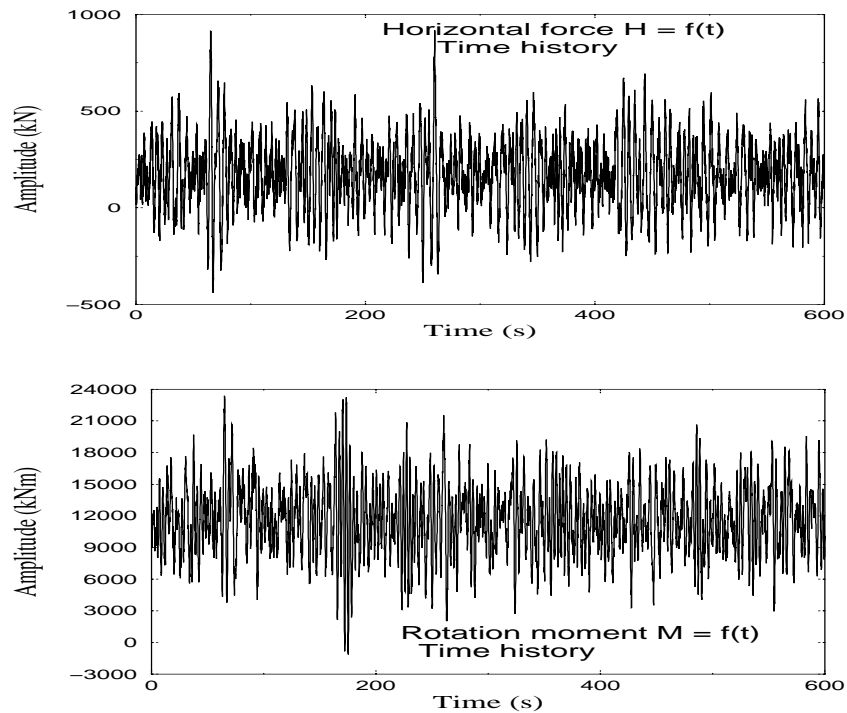

Figure 4 Dynamic loads applied at the top of the mono-pile windmill foundation

The mono-pile windmill foundation is considered to be subjected under the design horizontal vibration load  $H = f(t)$  and the rotation moment  $M = f(t)$  as given in Figure 4. These loads simulate the dynamic effects of wind and water waves at the pile top.

The calculations start by carrying out a spectrum analysis or Fourier analysis of both those loads [17]. A predominant frequency  $f = 0.25$  Hz or a predominant period  $T_p = 4$  s is chosen to define the size of the FEM model.

#### Absorbing boundary conditions

In the Direct Method of analyzing dynamic soil-structure-interaction problems the FEM model is terminated by transmitting boundary conditions. These boundary conditions must simulate the unbounded soil domain.

The rigorous boundary is global both in time and space and is described through differential and integral operators with respect to space and time. As this is computationally expensive different local schemes are developed.



These ‘mechanical devices’ are formulated using only differential operators with respect to space and time. A state of the art of different schemes is given in detail in [16]. A main characteristic of these formulations is that they are independent of the frequency of excitations. This advantage makes them applicable for time domain transient analysis, which corresponds to the current situation.

The formulation given from [16] is used in the current analysis. The boundary conditions are designed to handle different types of waves at different incidences encountered in halfspace or layered soil conditions. They are accurate for low and high level of vibration frequencies.

A consistent formulation of the boundary is adopted here taking into account the angle of wave incidence. A sensitivity analysis varying the shear wave velocity of the top layers and the material damping in the soil is carried out too as a continuation of [17] where a lumped formulation of the boundary was applied.

### **Calculations and results**

The calculations start directly with the embedded pile and the layered soil. The weight of the windmill superstructure is neglected. The pile is modeled as a solid material as in the static calculation. The soil is also modeled as for the static calculation but using only the elastic parameters.

The initial conditions are ignored as they are not important for the current dynamic system.. The horizontal load and vertical load are applied in discretized numerical form for time duration of 200 s.

In a time interval shorter than 4 s the deformations of the boundary nodes are almost zero. After this time interval deformations or velocities increase as the waves are continuing their way towards the far field.

When stress free boundary conditions or fixed boundary conditions were implemented, after almost 10 s the solution for the pile dynamic is spoiled and for 200 s no results could be derived. The reason for that is that the waves reaching the boundary after almost 4 s will return back in the model changing the dynamic of the pile-soil system.

The results from the numerical calculations are given in Figure 5, 6. A maximum pile top horizontal deformation of 6.7 mm is noted from this viscoelastic-dynamic calculation with a maximum horizontal velocity about 9 mm/s. The rotation angle resulted to be very small.

### **Conclusions**

A three-dimensional (3D) elastic-plastic and viscodynamic FEM of the mono-pile windmill foundation at Horns Rev in Denmark is carried out employing ABAQUES FEM and self-developed Axisymmetric FEM programs.

The static calculations are carried out for extreme static horizontal loads and rotation moment. Mohr-Coulomb constitutive soil behavior with some

hardening, based on the available design parameters derived from CPT and other tests is employed. Drucker-Prager model is implemented as an alternative too.

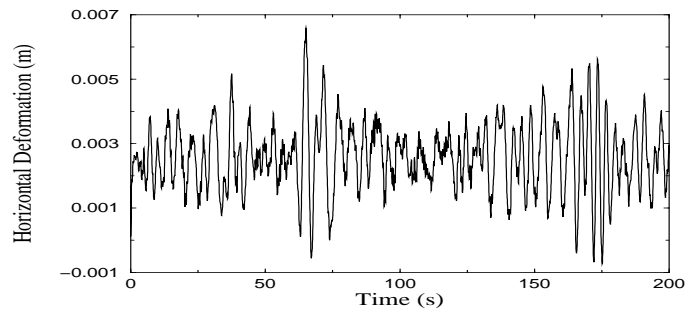

Figure 5 Horizontal deformation time variation at the top of the mono-pile.

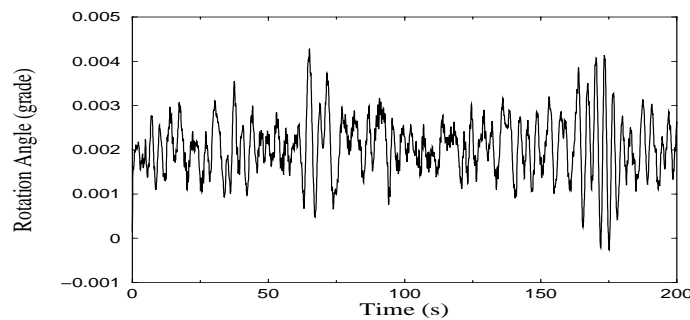

Figure 6 Rotation angle time variation at the top of the mono-pile.

Pile-soil interface is modeled. Different properties of the pile-soil contact were considered, as a sensitivity analysis. For the 22 m pile length the maximum horizontal deformation at the seabed level is evaluated to be 35 - 40 mm and the rotation angle 0.37 - 0.38°.

To investigate the dynamic of the mono-pile foundation a 3D axisymmetric dynamic FEM is carried out in time domain. Radiation damping is modeled employing consistent absorbing boundary conditions. Sensitivity analyses are carried out. The maximum amplitude for the horizontal deformation at the pile top is evaluated to be 6.7 mm and maximum velocity 9 mm/s during 200 s.

The static and dynamic analyses fulfill the requirements given at [18].

### Acknowledgment

The current work is carried out at GEO-Danish Geotechnical Institute. The authors are grateful to Tech-wise A/S, Fredericia, Denmark for supplying with the data for the applied loads and Fem-tech AB in Sweden for their support.

### References

1. Feld, T. *Suction buckets, a new innovative foundation concept applied to offshore wind turbines*. Ph.D thesis ATV Project EF675, Aalborg University, Denmark, 2001
2. Strandgaard, T. and Vandenbulcke, L. *Driving mono-piles into glacial till*. IBC's Wind Power Europe, 1-15, 2002
3. Garassino, A. L. *Some developments on laterally loaded piles with particular references to p-y subgrade reaction method*. 4th International DFI Conference, 759-770, 1994
4. Naggar, M. H. El. and Novak, M. *Nonlinear lateral interaction in pile dynamics*. Soil Dynamics and Earthquake Engineering 14, 141-157, 1995
5. Reese, L. C., Wang, S. T., Isenhower, W. M., and Arrellaga, J. A. *LPILE plus 4.0*, Technical manual, version 4.0 ed. ENSOFT, INC., Oct. 2000
6. Brown, D. A. and Shie, C. F. *Three dimensional finite element model of laterally loaded piles*. Computers and Geotechnics 10, 59-79, 1990
7. Brown, D. A. and Shie, C. F. *Some numerical experiments with a three-dimensional finite element model of laterally loaded piles*. Computers and Geotechnics 12, 149-162, 1991
8. Trochanis, A. M., Bielak, J. and Christiano, P. *Three-dimensional nonlinear study of piles*. Journal of Geotechnical Engineering. 117, 3, 429-447, 1991
9. Yang, Z., and Jeremic, B. *Nonlinear analysis of pile behavior under lateral loads in layered elastic-plastic soil*. International Journal for Numerical and Analytical Methods in Geomechanics, 1-31, 2002
10. Sen, R., Davis, T. G. and Banerjee, P. K. *Dynamic analysis of piles and pile groups embedded in homogeneous soil*. International Journal of Earthquake Engineering and Structural Dynamics, 13(1), 53-65, 1985
11. Kuhlemeyer, R. L. *Static and dynamic laterally loaded floating piles*. Journal of Geotechnical Engineering Division, ASCE 105(GT2), 325-330, 1979
12. Randolph, M. F. and Simons, H. A. *An improved soil model for one-dimensional pile driving analysis*. Proc. 3<sup>rd</sup> International Conference on Numerical Methods in Offshore Piling, Nantes, 1-17, 1986
13. Cai, Y. X., Gould, P. L. and Desai, C. S. *Nonlinear analysis of 3D seismic interaction of soil-pile-structure system and application*. Engineering Structures, 22(2), 191-199, 2000
14. Hibbit, Karlsson and Sorensen, Inc. *ABAQUS User Manual*, Version 6.2.
15. Li, X. S. and Dafalias Y.F. *Dilatancy for cohesionless soils*. Geotechnique 50, No 4, 449-460, 2000
16. Kellezi, L. *Transmitting Boundaries for Transient Elastic Analysis*. Journal of Soil Dynamics and Earthquake Engineering, Vol. 19, No. 7, 533-547, 2000
17. Kellezi, L and Hansen, P. B. *Dynamic transient analysis of a mono-pile windmill foundation*. EURO DYN2002 proceedings, 1315-1320, 2002
18. American Petroleum Institute Recommended practice for planning, designing and constructing fixed offshore platform. API (RP-2A), 1991